

KOE

JDI Group

Kaohsiung Opto-Electronics Inc.

FOR MESSRS : _____

DATE : May 10th, 2013

CUSTOMER'S ACCEPTANCE SPECIFICATIONS

TX14D24VM1BAA

Contents

No.	ITEM	SHEET No.	PAGE
1	COVER	7B64PS 2701-TX14D24VM1BAA-1	1-1/1
2	RECORD OF REVISION	7B64PS 2702-TX14D24VM1BAA-1	2-1/1
3	GENERAL DATA	7B64PS 2703-TX14D24VM1BAA-1	3-1/1
4	ABSOLUTE MAXIMUM RATINGS	7B64PS 2704-TX14D24VM1BAA-1	4-1/1
5	ELECTRICAL CHARACTERISTICS	7B64PS 2705-TX14D24VM1BAA-1	5-1/1
6	OPTICAL CHARACTERISTICS	7B64PS 2706-TX14D24VM1BAA-1	6-1/2~2/2
7	BLOCK DIAGRAM	7B64PS 2707-TX14D24VM1BAA-1	7-1/1
8	RELIABILITY TESTS	7B64PS 2708-TX14D24VM1BAA-1	8-1/1
9	LCD INTERFACE	7B64PS 2709-TX14D24VM1BAA-1	9-1/6~6/6
10	OUTLINE DIMENSIONS	7B64PS 2710-TX14D24VM1BAA-1	10-1/1
11	APPEARANCE STANDARD	7B64PS 2711-TX14D24VM1BAA-1	11-1/3~3/3
12	PRECAUTIONS	7B64PS 2712-TX14D24VM1BAA-1	12-1/1
13	DESIGNATION OF LOT MARK	7B64PS 2713-TX14D24VM1BAA-1	13-1/1

PROPOSED BY: 

2. RECORD OF REVISION

DATE	SHEET No.	SUMMARY

3. GENERAL DATA

3.1 DISPLAY FEATURES

This module is a 5.7" QVGA of 4:3 format amorphous silicon TFT. The pixel format is vertical stripe and sub pixels are arranged as R(red), G(green), B(blue) sequentially. This display is RoHS compliant, and COG (chip on glass) technology and LED backlight are applied on this display

Part Name	TX14D24VM1BAA
Module Dimensions	167.0(W) mm x 109.0(H) mm x 9.2(D) mm typ.
LCD Active Area	115.2(W) mm x 86.4(H) mm
Dot Pitch	0.12(W) mm x 3(R, G, B)(W) x 0.36(H) mm
Resolution	320 x 3(RGB)(W) x 240(H) dots
Color Pixel Arrangement	R, G, B Vertical stripe
LCD Type	Transmissive Color TFT; Normally White
Display Type	Active Matrix
Number of Colors	262k Colors
Backlight	15 LEDs (3 serial x 5)
Weight	168g typ.
Interface	C-MOS; 18-bit RGB; 40 pins
Power Supply Voltage	3.3V for LCD and Backlight
Power Consumption	380mW for LCD; 1030mW for B/L
Viewing Direction	6 O'clock (without image inversion and least brightness change) 12 O'clock (contrast peak located at)

4. ABSOLUTE MAXIMUM RATINGS

Item	Symbol	Min.	Max.	Unit	Remarks
Supply Voltage	V_{DD}	-0.3	5.0	V	-
Input Voltage of Logic	V_I	-0.2	$V_{DD} + 0.2$	V	Note 1
Operating Temperature	T_{op}	-30	80	°C	Note 2
Storage Temperature	T_{st}	-30	80	°C	Note 2

Note 1: The rating is defined for the signal voltages of the interface such as DE, DCLK and RGB data bus.

Note 2: The maximum rating is defined as above based on the panel surface temperature, which might be different from ambient temperature after assembling the panel into the application. Moreover, some temperature-related phenomenon as below needed to be noticed:

- Background color, contrast and response time would be different in temperatures other than 25°C.
- Operating under high temperature will shorten LED lifetime.

5. ELECTRICAL CHARACTERISTICS

5.1 LCD CHARACTERISTICS

$T_a = 25^\circ\text{C}$, $V_{SS} = 0\text{V}$

Item	Symbol	Condition	Min.	Typ.	Max.	Unit	Remarks
Power Supply Voltage	V_{DD}	-	3.0	3.3	3.6	V	-
Input Voltage of Logic	V_I	"H" level	$0.7V_{DD}$	-	V_{DD}	V	Note 1
		"L" level	V_{SS}	-	$0.3V_{DD}$		
Power Supply Current	I_{DD}	$V_{DD}-V_{SS}=3.3\text{V}$	-	115	130	mA	Note 2
Vsync Frequency	f_v	-	52	60	68	Hz	-
Hsync Frequency	f_H	-	13.1	15.2	17.7	KHz	-
DCLK Frequency	f_{CLK}	-	4.85	5.85	7.0	MHz	-

Note 1: The rating is defined for the signal voltages of the interface such as DE, DCLK, DIM and RGB data bus.

Note 2: An all black check pattern is used when measuring I_{DD} . f_v is set to 60 Hz.

Note 3: 1.0A fuse is applied in the module for I_{DD} . For display activation and protection purpose, power supply is recommended larger than 2.5A to start the display and break fuse once any short circuit occurred.

5.2 BACKLIGHT CHARACTERISTICS

$T_a = 25^\circ\text{C}$

Item	Symbol	Condition	Min.	Typ.	Max.	Unit	Remarks
Power Supply Voltage	V_{DD}	Backlight Unit	3.0	3.3	3.6	V	Note1
LED Forward Current (Dim Control)	I_{LED}	0V;0% duty	-	312	342	mA	Note2
		3.3VDC;100% duty	-	120	132		
LED Lifetime	-	312mA	-	50K	-	hrs	Note 3

Note 1: Fig. 5.1 shows the LED backlight circuit. The circuit has 15 LEDs in total and R is 200Ω .

Note 2: Dimming function can be obtained by applying DC voltage or PWM signal from the display interface CN1. The recommended PWM signal is 1K~10KHz with 3.3V amplitude.

Note 2: The estimated lifetime is specified as the time to reduce 50% brightness by applying 60mA at 25°C .

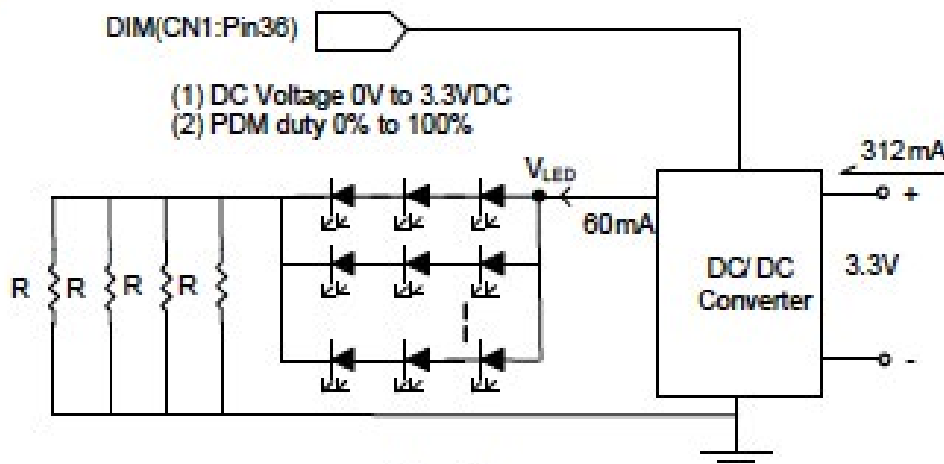

Fig. 5.1

6. OPTICAL CHARACTERISTICS

The optical characteristics are measured based on the conditions as below:

- Supplying the signals and voltages defined in the section of electrical characteristics.
- The backlight unit needs to be turned on for 30 minutes.
- The ambient temperature is 25°C.
- In the dark room around 500~1000 lx, the equipment has been set for the measurements as shown in Fig 6.1.

$T_a = 25^\circ\text{C}$, $f_s = 60\text{Hz}$, $V_{DD} = 3.3\text{V}$

Item	Symbol	Condition	Min.	Typ.	Max.	Unit	Remarks	
Brightness of White	-	$\phi = 0^\circ, \theta = 0^\circ$, $I_{LED} = 60\text{mA}$	360	450	-	cd/m^2	Note 1	
Brightness Uniformity	-		70	-	-	%	Note 2	
Contrast Ratio	CR		300	600	-	-	Note 3	
Response Time		$\phi = 0^\circ, \theta = 0^\circ$	-	45	-	ms	-	
NTSC Ratio	-	$\phi = 0^\circ, \theta = 0^\circ$	-	60	-	%	-	
Viewing Angle	θ_x	$\phi = 0^\circ, \text{CR} \geq 10$	50	60	-	Degree	Note 5	
	$\theta_{x'}$	$\phi = 180^\circ, \text{CR} \geq 10$	50	60	-			
	θ_y	$\phi = 90^\circ, \text{CR} \geq 10$	65	75	-			
	$\theta_{y'}$	$\phi = 270^\circ, \text{CR} \geq 10$	45	55	-			
Color Chromaticity	Red	X	$\phi = 0^\circ, \theta = 0^\circ$	0.58	0.63	0.68	-	Note 6
		Y		0.29	0.34	0.39		
	Green	X		0.32	0.37	0.42		
		Y		0.54	0.59	0.64		
	Blue	X		0.10	0.15	0.20		
		Y		0.04	0.09	0.14		
	White	X		0.26	0.31	0.36		
		Y		0.28	0.33	0.38		

Note 1: The brightness is measured from the center point of the panel, P5 in Fig. 6.2, for the typical value.

Note 2: The brightness uniformity is calculated by the equation as below:

$$\text{Brightness uniformity} = \frac{\text{Min. Brightness}}{\text{Max. Brightness}} \times 100\%$$

, which is based on the brightness values of the 9 points measured by BM-5 as shown in Fig. 6.2.

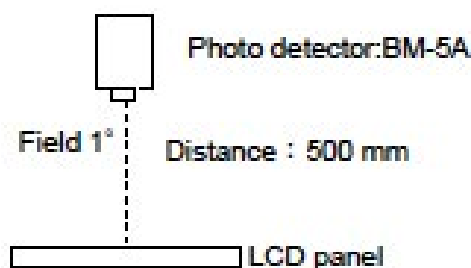

Fig. 6.1

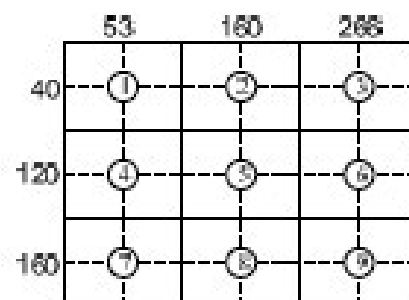

Fig. 6.2

Note 3: The Contrast ratio is measured from the center point of the panel, P5, and defined as the following equation:

$$CR = \frac{\text{Brightness of White}}{\text{Brightness of Black}}$$

Note 4: The definition of response time is shown in Fig. 6.3. The rising time is the period from 90% brightness to 10% brightness when the data is from white to black. Oppositely, Falling time is the period from 10% brightness rising to 90% brightness.

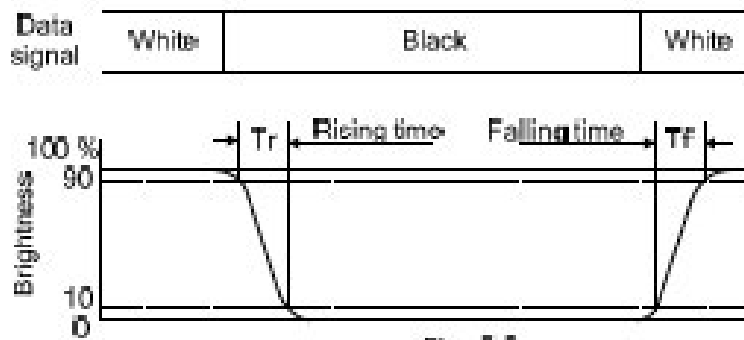

Fig. 6.3

Note 5: The definition of viewing angle is shown in Fig. 6.4. Angle ϕ is used to represent viewing directions, for instance, $\phi = 270^\circ$ means 6 o'clock, and $\phi = 0^\circ$ means 3 o'clock. Moreover, angle θ is used to represent viewing angles from axis Z toward plane XY.

The viewing direction of this display is 6 o'clock, which means that a photograph with gray scale would not be reversed in color and the brightness change would be less from this direction. However, the best contrast peak would be located at 12 o'clock.

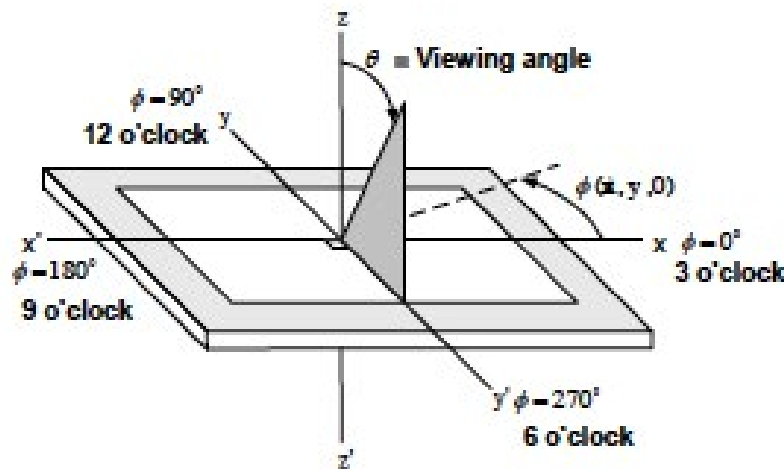
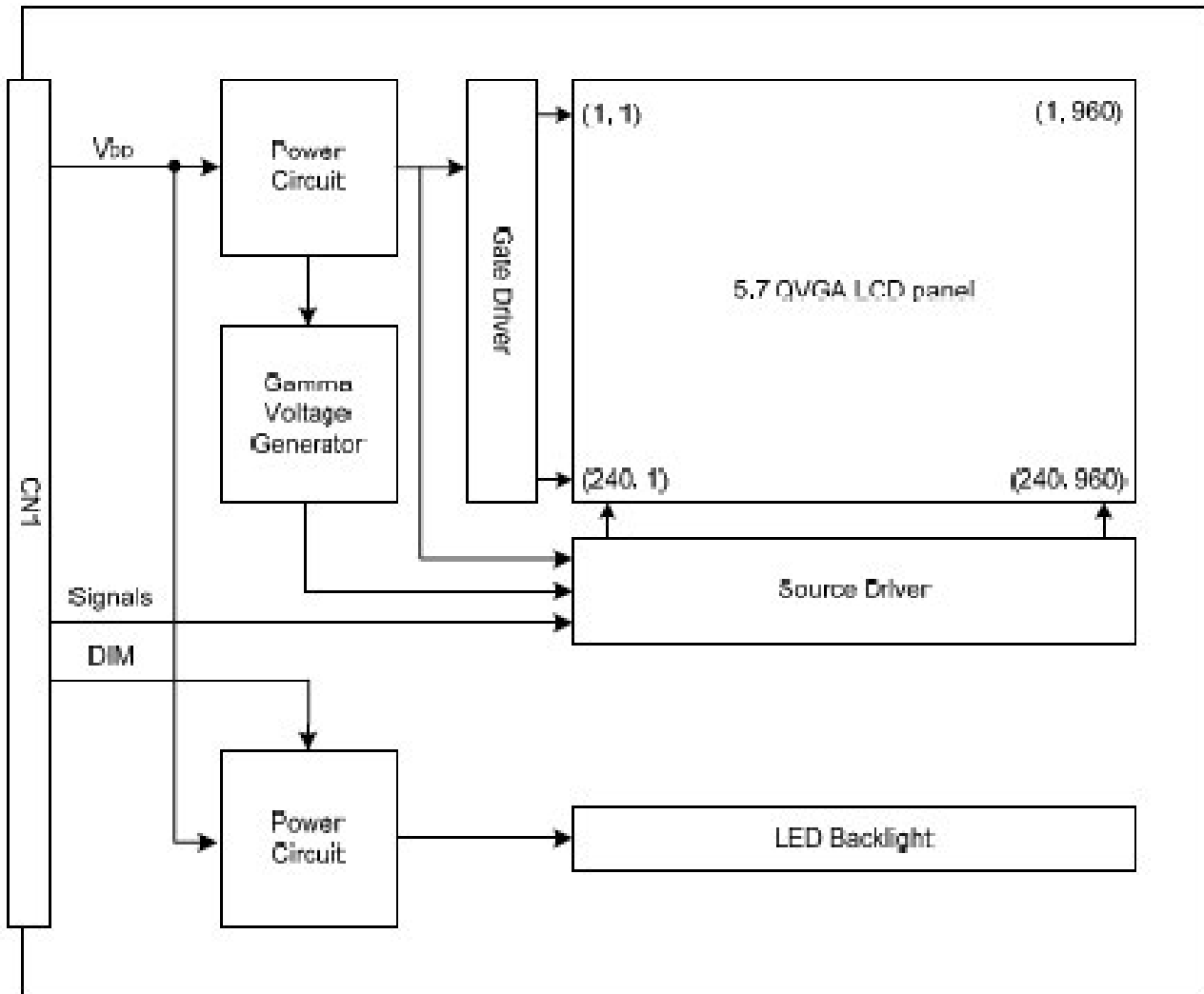

Fig. 6.4

Note 6: The color chromaticity is measured from the center point of the panel, P5, as shown in Fig. 6.2.

7. BLOCK DIAGRAM



Note 1: Signals are DCLK, DIM, DE and RGB data bus.

8. RELIABILITY TESTS

Test Item	Condition				
High Temperature	1) Operating	2) 80°C	240 hrs		
Low Temperature	1) Operating	2) -30°C	240 hrs		
High Temperature	1) Storage	2) 80°C	240 hrs		
Low Temperature	1) Storage	2) -30°C	240 hrs		
Heat Cycle	1) Operating	2) -20°C ~ 70°C	3) 3hrs ~ 1hr ~ 3hrs	240 hrs	
Thermal Shock	1) Non-Operating	2) -35°C ↔ 85°C	3) 0.5 hr ↔ 0.5 hr	240 hrs	
High Temperature & Humidity	1) Operating	2) 40°C & 85%RH	3) Without condensation (Note3)	240 hrs	
Vibration	1) Non-Operating	2) 20~200 Hz	3) 2G	4) X, Y, and Z directions	1 hr for each direction
Mechanical Shock	1) Non-Operating	2) 10 ms	3) 50G	4) ±X, ±Y and ±Z directions	Once for each direction
ESD	1) Operating	2) Tip: 200 pF, 250 Ω	3) Air discharge for glass: ± 8KV	4) Contact discharge for metal frame: ± 8KV	1) Glass: 9 points 2) Metal frame: 8 points (Note4)

Note 1: There is no display functionality failure occurred after the reliability tests.

Note 2: The display is not guaranteed for use in corrosive gas environments.

Note 3: Under the condition of high temperature & humidity, if the temperature is higher than 40°C, the humidity needs to be reduced as Fig. 8.1 shown.

Note 4: All pins of LCD interface (CN1) have been tested by ±100V contact discharge of ESD under non-operating condition.

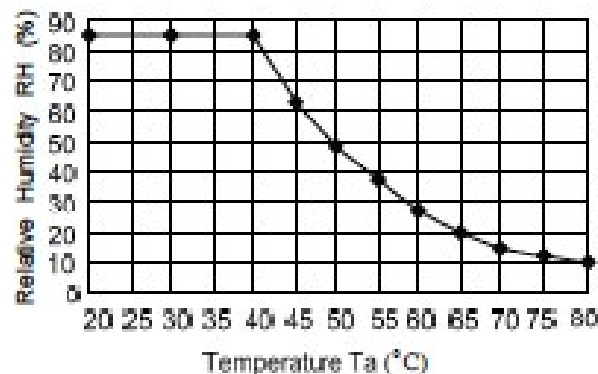

Fig. 8.1

9. LCD INTERFACE

9.1 INTERFACE PIN CONNECTIONS

The display interface connector is FA5B040HP1 made by JAE (Thickness: $0.3 \pm 0.05\text{mm}$; Pitch: $0.5 \pm 0.05\text{mm}$) and more details of the connector are shown in the section of outline dimension.

Pin assignment of LCD interface is as below:

Pin No.	Signal	Function	Pin No.	Signal	Function
1	V _{DD}	Power Supply for Logic	21	G4	Green Data
2	V _{DD}		22	G3	
3	V _{DD}		23	V _{SS}	GND
4	V _{DD}		24	G2	Green Data
5	NC	No Connection	25	G1	
6	DE	Timing Signal for Data	26	G0	Red Data
7	V _{SS}	GND	27	V _{SS}	
8	DCLK	Dot Clock	28	R5	Red Data
9	V _{SS}	GND	29	R4	
10	NC	No Connection	30	R3	
11	V _{SS}	GND	31	V _{SS}	GND
12	B5	Blue Data	32	R2	Red Data
13	B4				
14	B3				
15	V _{SS}	GND	35	NC	No Connection
16	B2	Blue Data	36	DIM	Note1
17	B1				
18	B0				
19	V _{SS}	GND	37	NC	No Connection
20	G5	Green Data	38	NC	
			39	NC	
			40	NC	

Note 1: Normal brightness: 0V or 0% PWM duty ; Brightness Control: 0V to 3.3V DC or 0% to 100% PWM duty.

9.2 TIMING CHART

A. DE MODE

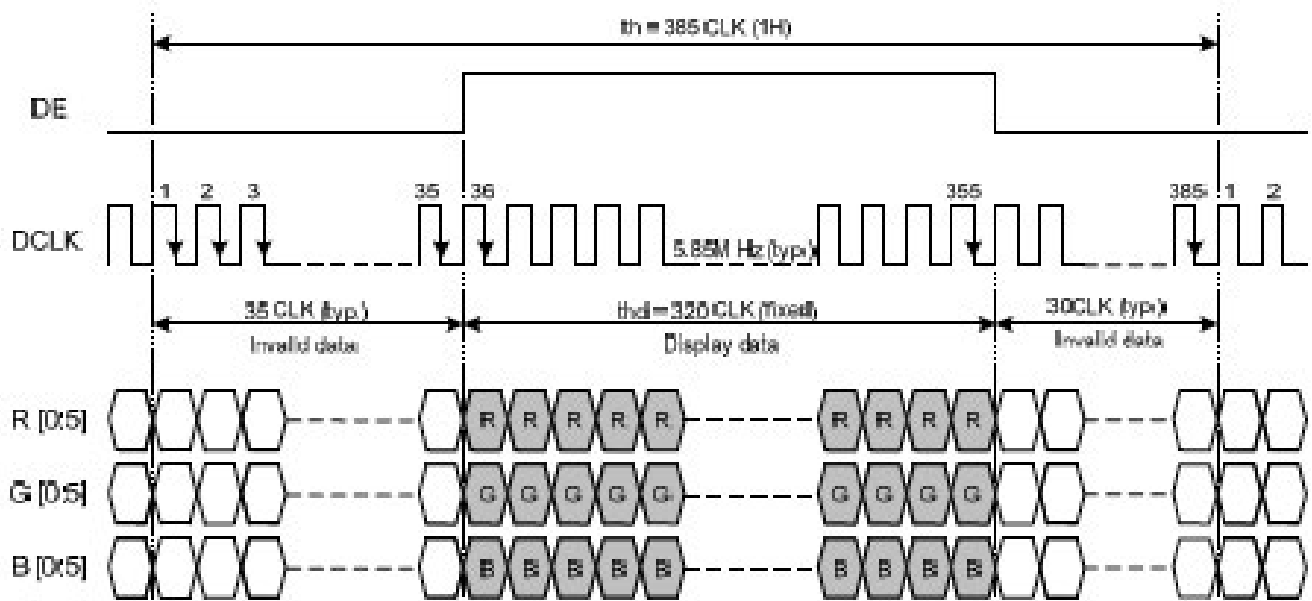

Fig. 9.1 Horizontal Timing

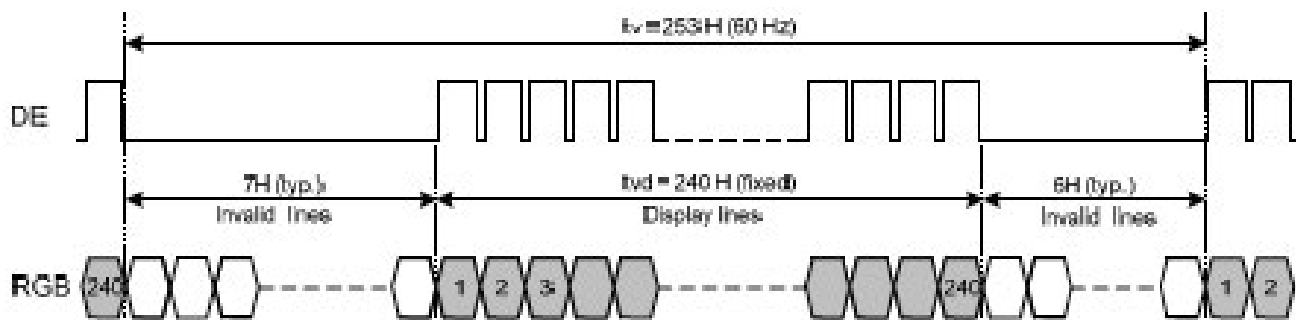

Fig. 9.2 Vertical Timing

B. CLOCK AND DATA INPUT TIMING

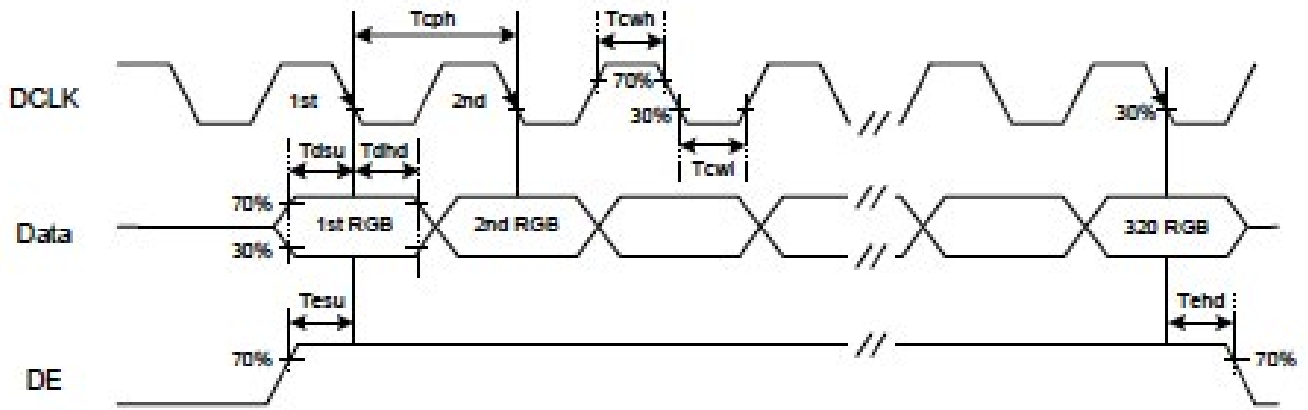

Fig. 9.3 Setup & Hold Time

9.3 TIME TABLE

The column of timing sets including minimum, typical, and maximum as below are based on the best optical performance, frame frequency (Vsync) = 60 Hz to define. If 60 Hz is not the aim to set, 54~60 Hz for Vsync is recommended to apply for better performance by other parameter combination as the definitions in section 5.1.

A. DE MODE

	Item	Symbol	Min.	Typ.	Max.	Unit
Horizontal	CLK Frequency	folk	5.58	5.85	6.2	M Hz
	Display Data	fhd	320	320	320	CLK
	Cycle Time	th	370	385	397	
Vertical	Display Data	tvd	240	240	240	H
	Cycle Time	tv	251	253	261	

B. CLOCK AND DATA INPUT TIMING

	Item	Symbol	Min.	Typ.	Max.	Unit
DCLK	Duty	Towh	40	50	60	%
	Cycle Time	Tcph	162	171	179	ns
Data	Setup Time	Tdsu	8	-	-	
	Hold Time	Tdhd	8	-	-	
DE	Setup Time	Tesu	8	-	-	
	Hold Time	Tehd	8	-	-	

9.4 POWER SEQUENCE

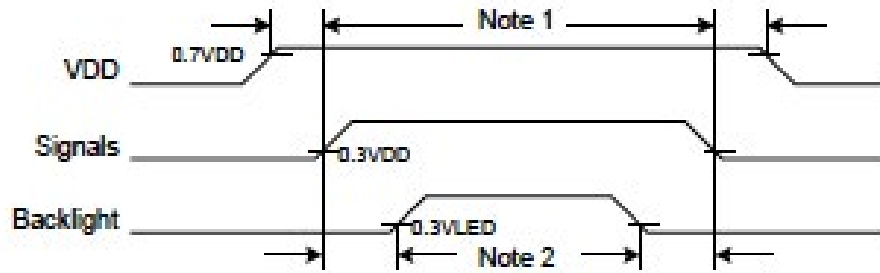

Fig. 9.4 Power Sequence Timing

Note 1: In order to avoid any damages, V_{DD} has to be applied before all other signals. The opposite is true for power Off where V_{DD} has to be remained on until all other signals have been switch off. The recommended time period is 1 second. Hot plugging might cause display damage due to incorrect power sequence, please pay attention on interface connecting before power on.

Note 2: In order to avoid showing uncompleted patterns in transient state. It is recommended that switching the backlight on is delayed for 1 second after the signals have been applied. The opposite is true for power Off where the backlight has to be switched off 1 second before the signals are removed.

9.5 DATA INPUT for DISPLAY COLOR

	COLOR & Gray Scale	Data Signal																	
		R5	R4	R3	R2	R1	R0	G5	G4	G3	G2	G1	G0	B5	B4	B3	B2	B1	B0
Basic Color	Black	0	0	0	0	0	0	0	0	0	0	0	0	0	0	0	0	0	0
	Red (63)	1	1	1	1	1	1	0	0	0	0	0	0	0	0	0	0	0	0
	Green (63)	0	0	0	0	0	0	1	1	1	1	1	1	0	0	0	0	0	0
	Blue (63)	0	0	0	0	0	0	0	0	0	0	0	0	1	1	1	1	1	1
	Cyan	0	0	0	0	0	0	1	1	1	1	1	1	1	1	1	1	1	1
	Magenta	1	1	1	1	1	1	0	0	0	0	0	0	1	1	1	1	1	1
	Yellow	1	1	1	1	1	1	1	1	1	1	1	1	0	0	0	0	0	0
	White	1	1	1	1	1	1	1	1	1	1	1	1	1	1	1	1	1	1
Red	Black	0	0	0	0	0	0	0	0	0	0	0	0	0	0	0	0	0	0
	Red (1)	0	0	0	0	0	1	0	0	0	0	0	0	0	0	0	0	0	0
	Red (2)	0	0	0	0	1	0	0	0	0	0	0	0	0	0	0	0	0	0
	:	:	:	:	:	:	:	:	:	:	:	:	:	:	:	:	:	:	:
	:	:	:	:	:	:	:	:	:	:	:	:	:	:	:	:	:	:	:
	Red (62)	1	1	1	1	1	0	0	0	0	0	0	0	0	0	0	0	0	0
	Red (63)	1	1	1	1	1	1	0	0	0	0	0	0	0	0	0	0	0	0
Green	Black	0	0	0	0	0	0	0	0	0	0	0	0	0	0	0	0	0	0
	Green (1)	0	0	0	0	0	0	0	0	0	0	0	1	0	0	0	0	0	0
	Green (2)	0	0	0	0	0	0	0	0	0	0	1	0	0	0	0	0	0	0
	:	:	:	:	:	:	:	:	:	:	:	:	:	:	:	:	:	:	:
	:	:	:	:	:	:	:	:	:	:	:	:	:	:	:	:	:	:	:
	Green (62)	0	0	0	0	0	0	1	1	1	1	1	0	0	0	0	0	0	0
	Green (63)	0	0	0	0	0	0	1	1	1	1	1	1	0	0	0	0	0	0
Blue	Black	0	0	0	0	0	0	0	0	0	0	0	0	0	0	0	0	0	0
	Blue (1)	0	0	0	0	0	0	0	0	0	0	0	0	0	0	0	0	0	1
	Blue (2)	0	0	0	0	0	0	0	0	0	0	0	0	0	0	0	0	1	0
	:	:	:	:	:	:	:	:	:	:	:	:	:	:	:	:	:	:	:
	:	:	:	:	:	:	:	:	:	:	:	:	:	:	:	:	:	:	:
	Blue (62)	0	0	0	0	0	0	0	0	0	0	0	0	1	1	1	1	1	0
Blue (63)	0	0	0	0	0	0	0	0	0	0	0	0	1	1	1	1	1	1	

10. OUTLINE DIMENSIONS

10.1 FRONT VIEW

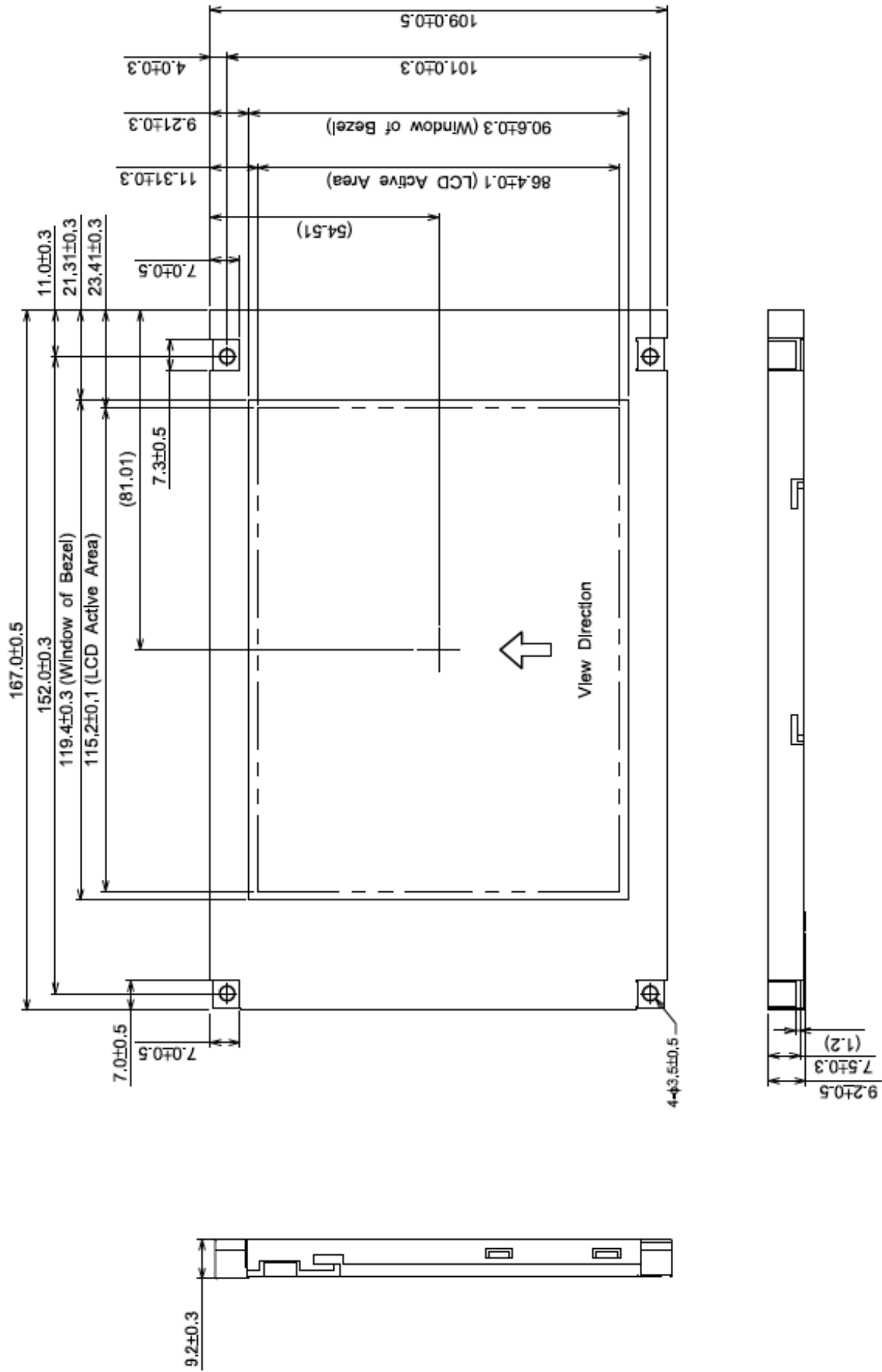

Scale : NTS
Unit : mm

10.2 REAR VIEW

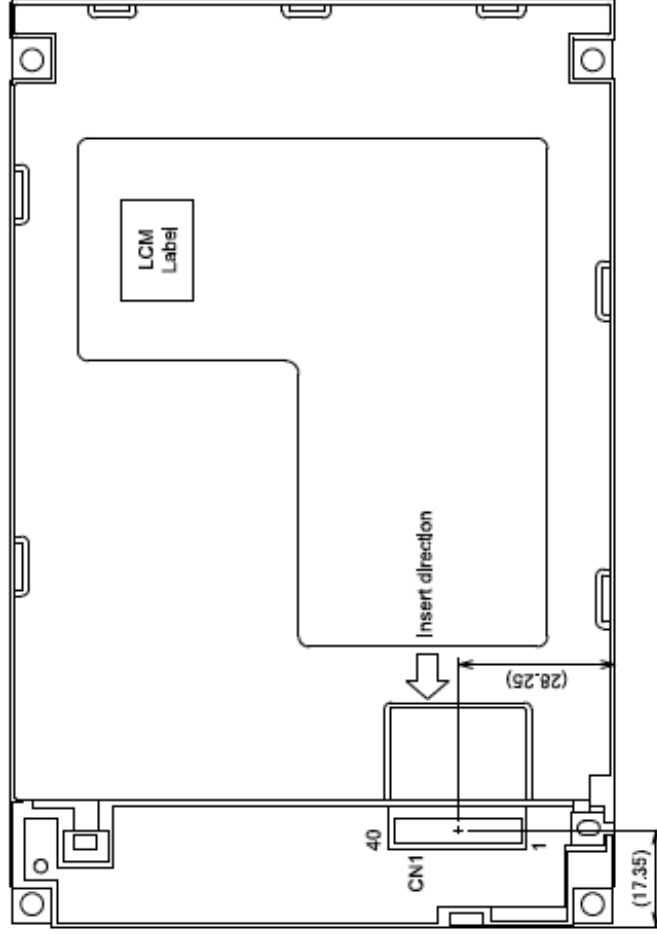

Recommended design rule for CN1 FPC

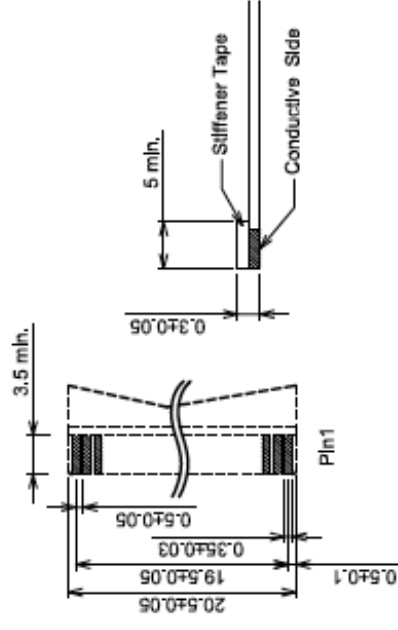

Scale : NTS
Unit : mm

Note 1) CN1 : FA5B040HP1

11. APPEARANCE STANDARD

The appearance inspection is performed in a dark room around 500~1000 lx based on the conditions as below:

- The distance between inspector's eyes and display is 30 cm.
- The viewing zone is defined with angle θ shown in Fig. 11.1 The inspection should be performed within 45° when display is shut down. The inspection should be performed within 5° when display is power on.

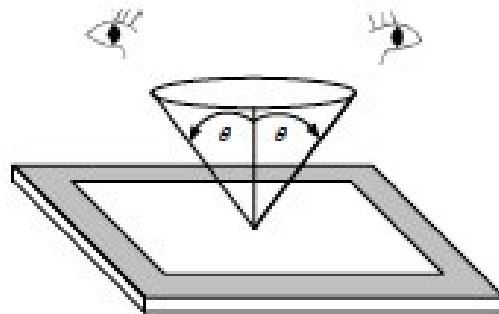

Fig. 11.1

11.1 THE DEFINITION OF LCD ZONE

LCD panel is divided into 2 areas as shown in Fig. 11.2 for appearance specification in next section. A zone is the LCD active area (dot area); B zone is the area between A zone and metal frame.

In terms of housing design, B zone is the recommended window area customers' housing should be located in.

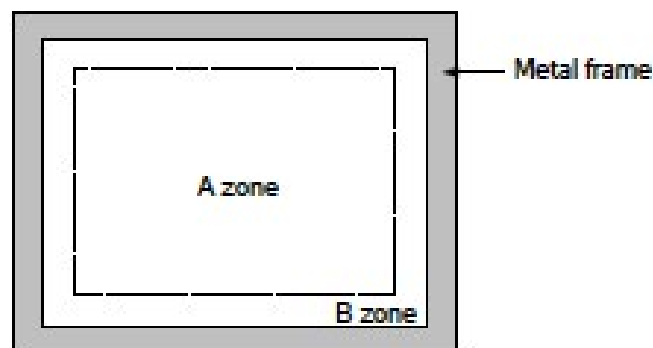

Fig. 11.2

11.2 LCD APPEARANCE SPECIFICATION

The specification as below is defined as the amount of unexpected phenomenon or material in different zones of LCD panel. The definitions of length, width and average diameter using in the table are shown in Fig. 11.4 and Fig. 11.5.

Item	Criteria				Applied zone
	Length (mm)	Width (mm)	Maximum number	Minimum space	
Scratches	$L \leq 15$	$W \leq 0.02$	Ignored	-	A
	$L \leq 15$	$0.02 < W \leq 0.1$	5	-	
	$L > 15$	$0.1 < W$	0	-	
Dent	Serious one is not allowed				A
Wrinkles in polarizer	Serious one is not allowed				A
Bubbles on polarizer	Average diameter (mm)		Maximum number		A
	$D \leq 0.3$		Ignored		
	$0.3 < D \leq 0.6$		4		
	$0.6 < D$		0		
1) Stains 2) Foreign Materials 3) Dark Spot	Filamentous (Line shape)				A
	Length (mm)	Width (mm)	Maximum number		
	$L \leq 2.0$	$W \leq 1.5$	5		
	$L > 2.0$	$1.5 < W$	0		
	Round (Dot shape)				A
	Average diameter (mm)	Maximum number	Minimum Space		
	$D \leq 0.2$	Ignored	-		
	$0.2 < D < 0.6$	4	-		
	$0.6 \leq D$	0	-		
	Those wiped out easily are acceptable				A (Note 1)
Dot-Defect		Area①	Area②	Maximum number	
	Bright dot-defect	1 dot	2 dot	3 dot	
	Dark dot-defect	2 dot	3 dot	4 dot	
	Bright + Dark point	3 dot	4 dot	5 dot	

Note 1: The Dot-Defect inspection within A zone (active area) would be divided into area ①, ② as Fig. 11.3 shown.

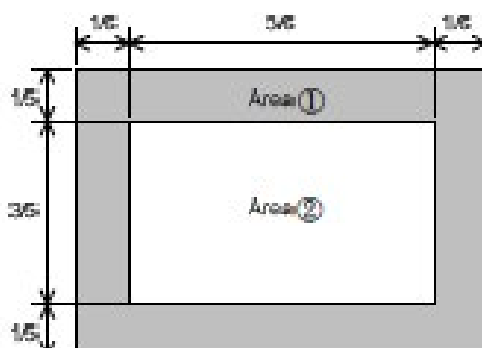

Fig. 11.3

LED BACKLIGHT APPEARANCE

Item	Criteria			Applied zone
Dark Spots White Spots Foreign Materials (Spot)	Average diameter (mm)	Maximum number		A
	$D \leq 0.4$	Ignored		
	$0.4 < D$	None		
Foreign Materials (Line)	Width (mm)	Length (mm)	Maximum number	A
	$W \leq 0.2$	$L \leq 2.5$	1	
		$2.5 < L$	None	
$0.2 < W$	-	None		
Scratches	Width (mm)	Length (mm)	Maximum number	A
	$W \leq 0.1$	-	Ignored	
		$0.1 < W \leq 0.2$	$L \leq 11.0$	
	$0.2 < W$	-	None	

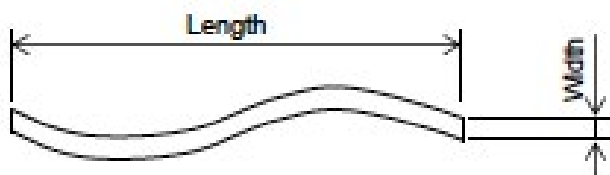

Fig 11.4



Fig 11.5

12. PRECAUTIONS

12.1 PRECAUTIONS OF ESD

- 1) Before handling the display, please ensure your body has been connected to ground to avoid any damages by ESD. Also, do not touch display's interface directly when assembling.
- 2) Please remove the protection film very slowly before turning on the display to avoid generating ESD.

12.2 PRECAUTIONS OF HANDLING

- 1) In order to keep the appearance of display in good condition; please do not rub any surfaces of the displays by sharp tools harder than 3H, especially touch panel, metal frame and polarizer.
- 2) Please do not pile the displays in order to avoid any scars leaving on the display. In order to avoid any injuries, please pay more attention for the edges of glasses and metal frame, and wear finger cots to protect yourself and the display before working on it.
- 3) Touching the display area or the terminal pins with bare hand is prohibited. This is because it will stain the display area and cause poor insulation between terminal pins, and might affect display's electrical characteristics furthermore.
- 4) Do not use any harmful chemicals such as acetone, toluene, and isopropyl alcohol to clean display's surfaces.
- 5) Please use soft cloth or absorbent cotton with ethanol to clean the display by gently wiping. Moreover, when wiping the display, please wipe it by horizontal or vertical direction instead of circling to prevent leaving scars on the display's surface, especially polarizer.
- 6) Please wipe any unknown liquids immediately such as saliva, water or dew on the display to avoid color fading or any permanently damages.
- 7) Maximum pressure to the surface of the display must be less than 1.96×10^4 Pa. If the area of adding pressure is less than 1 cm^2 , the maximum pressure must be less than 1.96N.

12.3 PRECAUTIONS OF OPERATING

- 1) Please input signals and voltages to the displays according to the values defined in the section of electrical characteristics to obtain the best performance. Any voltages over than absolute maximum rating will cause permanent damages to this display. Also, any timing of the signals out of this specification would cause unexpected performance.
- 2) When the display is operating at significant low temperature, the response time will be slower than it at 25 C° . In high temperature, the color will be slightly dark and blue compared to original pattern. However, these are temperature-related phenomenon of LCD and it will not cause permanent damages to the display when used within the operating temperature.
- 3) The use of screen saver or sleep mode is recommended when static images are likely for long periods of time. This is to avoid the possibility of image sticking.
- 4) Spike noise can cause malfunction of the circuit. The recommended limitation of spike noise is no bigger than $\pm 100 \text{ mV}$.

13. DESIGNATION of LOT MARK

1) The lot mark is showing in Fig.13.3. First 4 digits are used to represent production lot, T represented made in Taiwan, and the last 6 digits are the serial number.

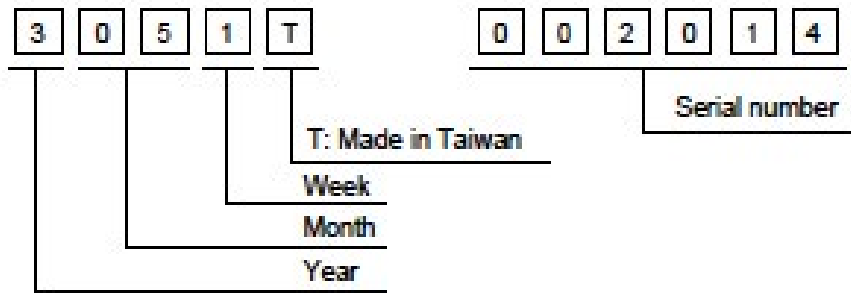

2) The tables as below are showing what the first 4 digits of lot mark are shorted for.

Year	Mark
2013	3
2014	4
2015	5
2016	6
2017	7

Month	Mark	Month	Mark
1	01	7	07
2	02	8	08
3	03	9	09
4	04	10	10
5	05	11	11
6	06	12	12

Week (Days)	Mark
1~7	1
8~14	2
15~21	3
22~28	4
29~31	5

3) Except letters I and O, revision number will be shown on lot mark and following letters A to Z.

4) The location of the lot mark is on the back of the display shown in Fig. 13.3.



Fig 13.3