

PREPARED BY: _____ DATE _____	<h1>SHARP</h1> <p>LIQUID CRYSTAL DISPLAY GROUP SHARP CORPORATION</p> <h2>SPECIFICATION</h2>	SPEC No. LA-04302F
APPROVED BY: _____ DATE _____		FILE No. _____
		ISSUE Jul. 14. '94
		PAGE 19
		APPLICABLE DIVISION
		<input type="checkbox"/> DUTY DEVELOPMENT CENTER
		<input type="checkbox"/> TFT DEVELOPMENT CENTER
		<input type="checkbox"/> LCD PRODUCTS DEVELOPMENT CENTER
		<input checked="" type="checkbox"/> EL PRODUCTION DEPT.

REQU29 MARS 1996

SPECIFICATION FOR  
EL Display Unit  
MODEL No. L J 6 4 O U 3 4

CUSTOMER'S APPROVAL

DATE \_\_\_\_\_

BY \_\_\_\_\_

PRESENTED

BY H. Kishishita

H. Kishishita  
Department General Manager  
EL Production Department  
Nara Factory  
Liquid Crystal Display Group  
SHARP CORPORATION

**SHARP**

MODEL No " LJ 6 4 0 U 3 4

## RECORDS OF REVISION

DOC. FIRST ISSUE

IDENT. DATA No.

DATE	REF. PAGE PARAGRAPH DRAWING No.	REVISED No	SUMMARY	CHECK & APPROVAL
Dec. 15. '92	Page 2 Page 2,3 Page 3,4	A A A	Add Note 1) : Survival temperature. Add the figure based on SI units. Change the symbol of luminance ) B → L	T. Okba
May. 31. '93	Page 12	A	Add item 6 to Cautions or Operat on.	T. Okba
Nov. 2. '93	Page 2,3,7 Page 1,3,11 Page 13	A A A	Elimination of former units. According as the revised LCD group standards Change the ratings. 500 → 800 :	H. Kurohata
Feb. 1. '94	Page 8	A	Correct errors. Terminal No. 5,6 GND → NC	H. Kurohata
May. 12, '9	Page 1	A	Correct errors. Interfase signal (H and L). "	H. Kurohata
Jul. 14. '94	Page 11 Page 13	A A	Revision of drawing. Changes of fuse model.	H. Kurohata

**SHARP**

## 1. Application

This data sheet is to introduce the specification of EL display unit,  
**LJ640U34**

## 2. overview

The Sharp EL display unit consists of a thin film EL panel, high voltage **MOS ICs** for panel driving and a display control **circuit**. By supplying five input signals of LS TTL **level** and two DC power supplies of +5 V and +12 V arbitrary graphs and characters can be displayed.

## 3. Mechanical Specifications

Parameter	Specification	Unit
	<b>Width × height × Depth</b>	
Outline	246 x 158 x 26	mm
Number of matrix electrodes	640 x 400	--
△ Active area	191.9 x 119.9	mm
Dot pitch	0.3 x 0.3	mm
Dot pitch ratio	1 x 1	mm
Dot size	0.22 x 0.22	mm
Weight	540	g

## 4. Absolute Maximum Ratings

4-1 Electrical **absolute** maximum ratings △<sup>9</sup> - (Ta=25 °C)

Parameter	Symbol	Rating	Unit
Interface signal (Logic "N")	V <sub>IN</sub>	V <sub>L</sub> +0.3	v
Interface signal (Logic "L")	V <sub>IL</sub>	-0.3	v
Supply voltage (Logic)	V <sub>I</sub>	+7	v
Supply voltage (panel drive)	V <sub>+</sub>	+14	v

**SHARP**4-2 Environmental conditions 

Parameter	Tstg		Topr A Note 1)		Remark
	Min.	Max.	Min.	Max.	
Ambient temperature	-40 °C	180 °C	-5 °C	+55 °C	
Humidity	Note 2)		Note 2)		No condensation
Vibration	Note 3)				No operating
Shock	Note 4)				No operating

Note 1) Survival temperature: -20 °C to 65 °C

No permanent damage will occur.

Note 2)  $T_a \leq 40 \text{ °C}$  ..... 95 % RH Max

$T_a > 40 \text{ °C}$  ..... Absolute humidity shall be less than

$T_a = 40 \text{ °C} / 95 \% \text{ RH}$ .

Note 3) 5 ~ 55 Hz Frequency range

Sweep time : 15 min each axis

Dwell at resonance : 10 min each resonance

Peak-to-peak

amplitude : 3.17 mm over 5 ~ 10 Hz range

: 1.52 mm over 10 ~ 25 Hz range

: 0.38 mm over 25 ~ 55 Hz range

55 ~ 500 Hz Frequency range

Sweep time : 120 min each axis

Dwell at resonance : 30 min each resonance

Peak-to-peak

amplitude : 30 m/s<sup>2</sup> peak acceleration

Note 4) Acceleration : 981 m/s<sup>2</sup>\*

Pulse width : 4 ms

3 times for each direction of ±X/±Y/±Z.

## 5. Electrical Characteristics

(Ta=25 °C)

Parameter	Symbol	Rating			Unit
		Min.	Typ.	Max.	
Supply voltage (Logic)	$V_L$	+4.75	+5.0	+5.25	V
Supply current (Logic, $V_L = +5 \text{ V}$ )	$I_L$	70	-	350	mA
Supply voltage (Panel drive)	$V_D$	+11.4	+12.0	+12.6	V
Supply current (Panel drive, $V_D = +12 \text{ V}$ )	$I_D$	40(±1)	-	1350	mA
Total power ( $V_L = +5 \text{ V}$ , $V_D = +12 \text{ V}$ )	$P_T$	-	11	-	W

(±1) 10 mA in condition with no signals nor  $V_L$  supplying.

**SHARP**

6. Optical Characteristics  $\triangle$

(Ta=25 °C)

Parameter	Symbol	Condition	Min.	Typ.	Max.	Unit	Remark
Luminance	$L_{ON}$	All dots lit	68.5	115	-	cd/m <sup>2</sup>	Note 1)
OFF luminance	$L_{OFF}$	All dots turned off	-	-	3.4	cd/m <sup>2</sup>	
Luminance distribution	$\Delta L_{DIS}$	All dots lit	-	-	30	%	
Fill factor			-	0.54	-		Note 2)
Shadowing characteristics	$\Delta L_{SD}$	fixed pattern	-	2	-	%	Note 3)
Viewing angle			-	160	-	°	

Note 1) Average luminance <sup>m</sup> measured at the five circular windows (R1~R5) shown in Fig.1 (Circular window diameter:  $\phi 13$  mm)

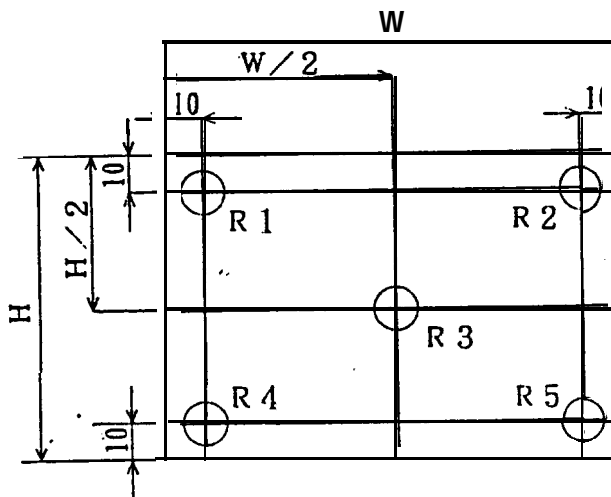

Fig. 1

H 119.9 : Height of active area  $\triangle$   
W 191.9 : Width of active area  
Unit :  $\mu$ m  
Tolerance:  $\pm 10\%$

The following formula defines the luminance distribution:

$$\Delta L_{DIS} = \left( 1 - \frac{L_{MIN}}{L_{MAX}} \right) \times 100 (\%)$$

where  $L_{MAX}$  is the maximum luminance and  $L_{MIN}$  is the minimum luminance taken at the five locations in Fig.1.

**SHARP**

Note 2) The ratio of the emission area to the display area. .... SHARP'S EL has comparatively high fill factor, and therefore, the visibility of display is excellent.

Note 3) Shadowing characteristics means the variation of luminance according to the number of dots lit on a scanning line.

Thanks to the addition of the shadowing compensation circuit, the display quality of SHARP'S EL is improved.

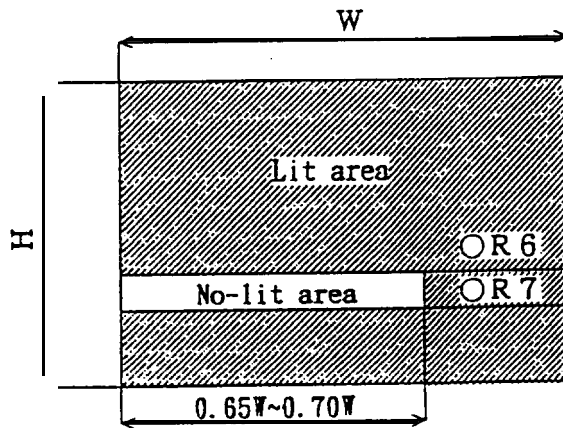

Fig. 2

The following formula defines the shadowing characteristics:

$$A L_{SD} = \left( \frac{L_N}{L_L} - 1 \right) \times 100 \quad (\%) \quad \Delta$$

where  $L_L$  is the luminance at R6,  $L_N$  at R7.

**SHARP**

## 7. Timing Characteristics

## 7-1 Input signal

This unit is driven by line-at-a-time scanning method with the following 5 input signals fed at LS TTL level.

Parameter	Symbol	Description
Data transfer clock	$CK_D$	The signal control sampling and transferring data signal.
Data signal	$D_{IN0}$ $D_{IN1}$	The signal are sampled at every rising edge of data transfer clock and are transferred in the direction of sequential row from the right end to left end. The display is on while the logic is "H" and off while the logic is "L".
Horizontal sync. signal	$\overline{H.D}$	The signal control the timing of line-at-a-time scanning. The display data remain in effect while the logic is "H" and blanking while the logic is "L".
Vertical sync. signal	$\overline{V.D}$	The signal controls frame frequency. Typ. 60 Hz Frame starts when the logic rises to "H" from "L"

SHARP

## 7-2 Input signals timing characteristics

(Ta=25 °C)

Parameter	symbol	Min.	TYP.	Max.	unit
clock frequency	$1/T_{cL}$	7.5	-	11	MHz
clock duty Note 1)	$T_{cL(H)}/T_{cL} \times 100$	45	-	55	%
Horizontal sync. signal cycle time	$T_H$	40	-	45	$\mu s$
Horizontal sync. signal blanking time	$t_{HB}$	2	-	-	$\mu s$
Vertical sync. signal, blanking time	$t_{VB}$	1	-	$N \times T_H$	$\mu s$
Vertical sync. signal valid time Note 2)	$t_{VA}$	$400 \times T_H$	-	-	$\mu s$
Frame Frequency	$1/T_V$	55	60	62	Hz
Data signal setup time	$t_{DS}$	20	-	-	ns
Data signal hold time	$t_{DH}$	20	-	-	ns
Horizontal sync. signal set-up time	$t_{HS}$	20	-	$T_{cL}/2$	ns
Horizontal sync. signal hold time	$t_{HD}$	20	-	$T_{cL}/2$	ns
Vertical sync. signal rise wait time	$t_{VR}$	4X40	-	-	$\mu s$
Vertical sync. rise timing	$t_{VH}$	40	-	$T_H - t_{HB} + 35$	$\mu s$

Note 1),

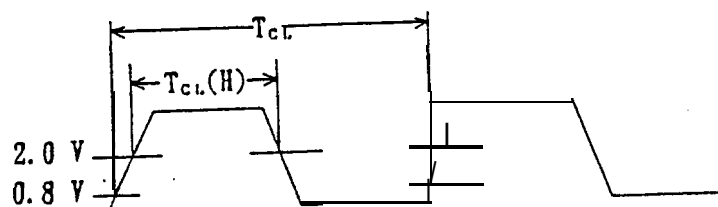

Note 2) The condition of  $t_{VA} \geq 400 \times T_H$  shall be strictly obeyed. Negligent of this condition can cause troubles of the unit even if the other conditions listed above are followed.

Note 3) Keep the Valid time of display data ( $t_{DH}$ ) to  $320 \times T_{cL}$ .



8. Timing Chart

Interface Timing and Display drive timing

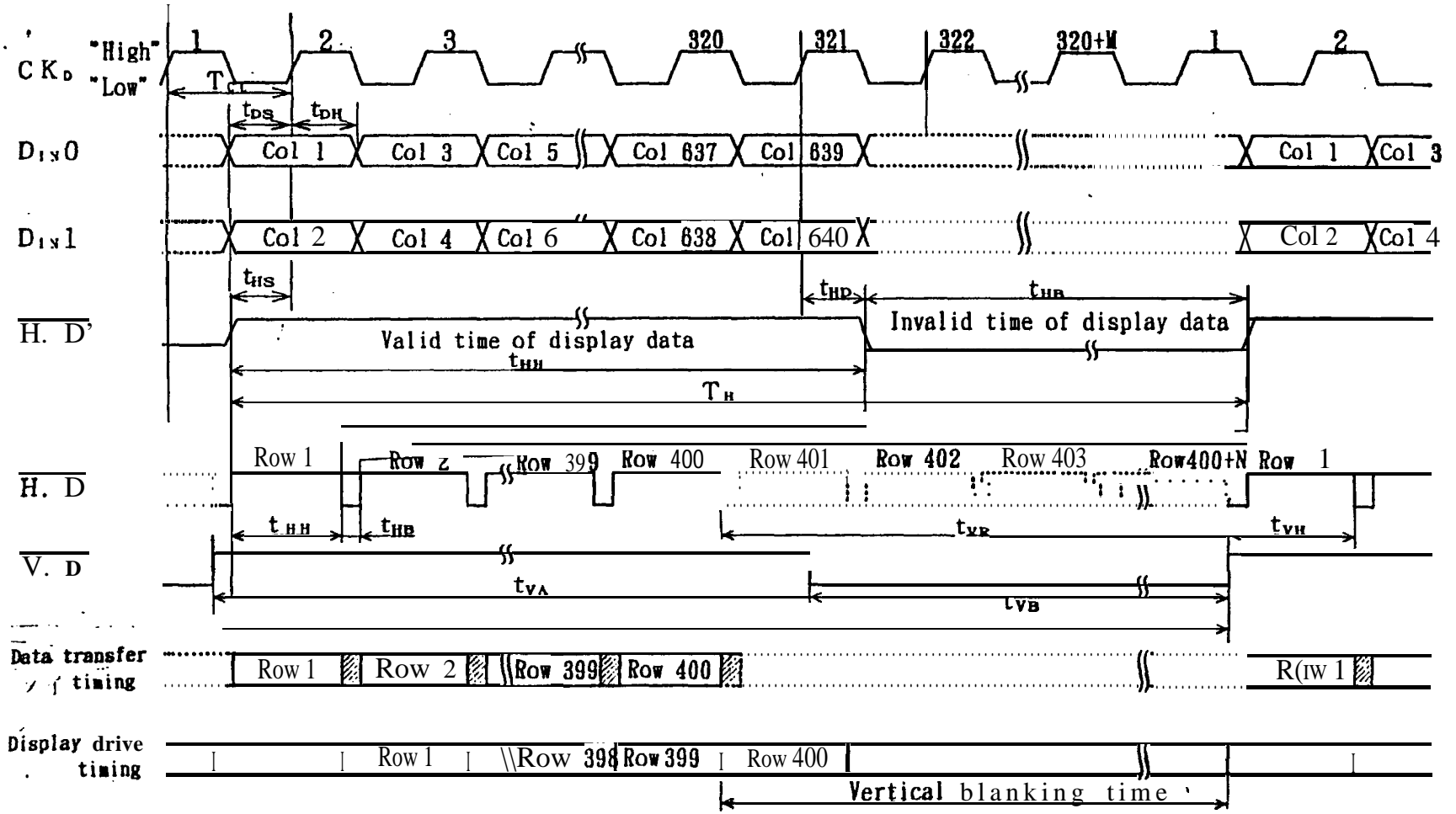

Note 1) Logic level is not necessary to be specified in dotted line portion.

Note 2)  $t_{HB} \geq 2 \mu s$  shall be kept. ( $t_{HB} = M \times T_{CL}$ )

Note 3)  $N \geq 4$  shall be kept.

**SHARP****9. Interface signal and power Supply Connectors**

Terminal No.	Signal name	Terminal No.	Signal name
15	Data signal for odd column ( $D_{1N0}$ )	16	Data signal for even column ( $D_{1N1}$ )
13	Data transfer clock ( $CK_D$ ) "	14	GND
11	Horizontal sync. signal ( $\overline{H.D}$ )	12	GND
9	Vertical sync. signal ( $\overline{V.D}$ )	10	NC
7	GND	8	GND
5	NC,	6	NC'
3	$V_L(+5\text{ v})$	4	$V_L(+5\text{ V})$
1	$V_D(+12\text{ v})$	2	$V_D(+12\text{ V})$



Unit-side pin header  
(16-pin board)

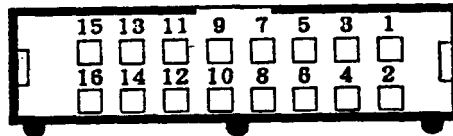

Fitting socket  
(16-pin solderless type, it's not included in the unit.)

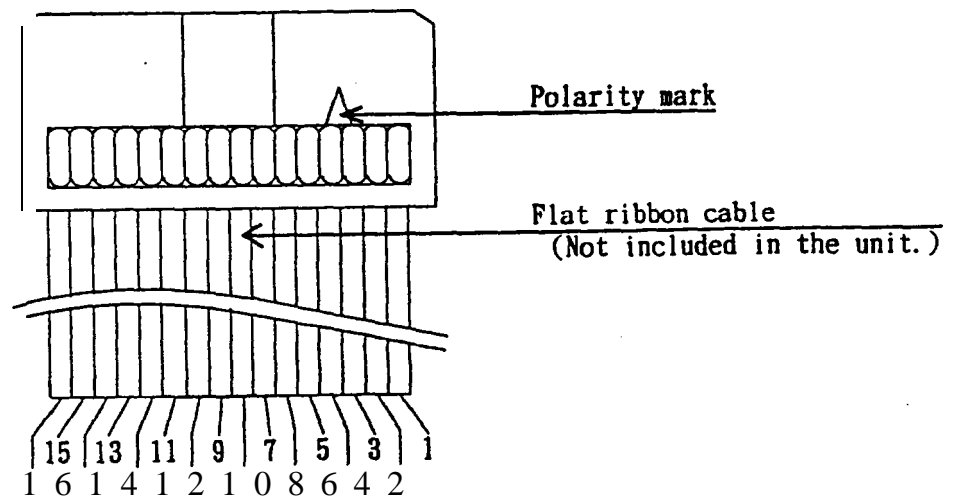

**SHARP****Connectors**

	<b>Model No.</b>	<b>Maker</b>
Unit-side pin header	HIF3FC-16PA-2.54DS or equivalents	HIROSE ELECTRIC CO.
Fitting socket	HIF3BA-16D-2.54R or equivalents	-ditto -

Note 1) The length of the cable shall not exceed 50 cm.

Note 2) This unit is not supplied with the socket and the cable.

**SHARP**

10. Functional Block Diagram

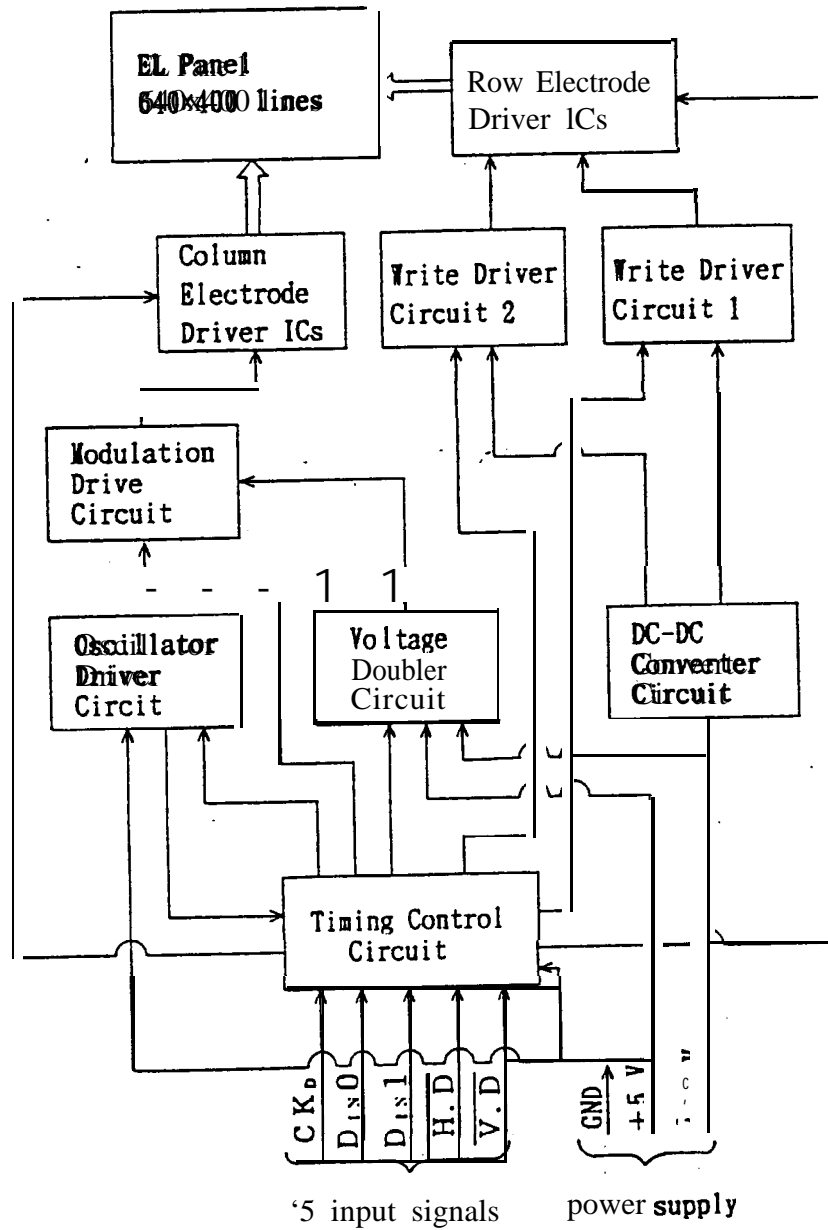

**SHARP**

11. Outline of the unit configuration  $\Delta$

This unit is shipped with the form drawing below.

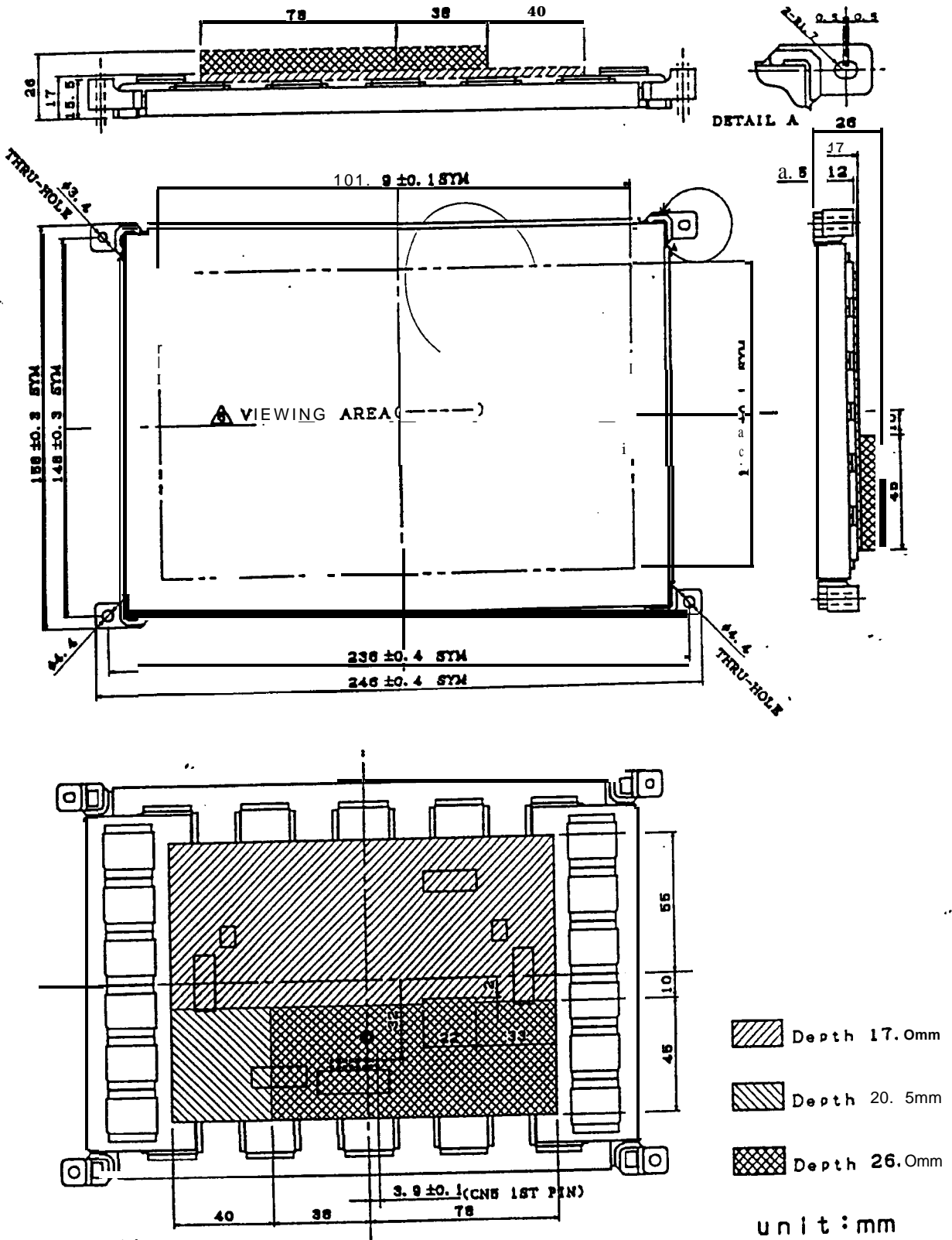

**SHARP****12. Handling Instructions and Cautions for Operation**Handling Instructions

1. Handle the unit with care of ESD. The operator and the place around him must be guard against ESD.  
Hold the mounting arms of 4 corners of the unit when you handle it.
2. Since the EL panel is made of glass, care shall be taken to avoid the breakage caused by dropping or bumping it.
3. The display control board or the frame of the unit shall not be removed nor the unit shall be disassembled. ICs mounted on the unit shall never be touched by finger/hands to prevent the breakage due to static electricity.

Cautions for Operation

1. The unit shall be operated within the rated operating conditions specified in this literature.  
Then you mount the unit on your product, design your product making the unit breathable.
2. Operation of the unit at high temperature with high humidity shall be strictly avoided.  
Dew on the connector or on the circuits will cause malfunction, which can lead damage to the unit.
3. Cable for the interface and power supplies shall be flat ribbon cable of 16 wires of 1.27 mm pitch (conductor ATC #28) or its equivalent.
4. The display control board on the rear side of the unit shall never be touched while in operation. It generates AC pulse of approx. 200 V.
5. This unit may occur the visible noise in case you set up it in a metal case. It is caused by the capacitance coupling between panel electrodes a metal case.  
In such a case, you should connect the wire from signal-GND with a metal Case.
- △ 6. To avoid the image retention caused by the luminance change due to time lapse, and to increase the panel life, please pay attention to the design of display, so that a fixed pattern may not be displayed as possible as you can, and by using all parts of the viewing area evenly.  
Also, we would recommend to use the unit at the ambient temperature as low as you can because the temperature is one of the causes of acceleration of the luminance change due to time lapse.

others:

If any problem should arise from this specification, the supplier and user should work out a mutually acceptable solution.

**SHARP**14. **Power supply** input circuit

## (a) Over. current protection

This unit equips fuses in **power supply** input circuit protecting fire accident rising **from** over current in internal circuit, so the fuse  ay melt down when the specifications are not kept or in case of short circuit.

Fuse specifications  $\Delta$ 

Parts No.	Model No.	Rat ings	Melt type	Authorizaition Standard
<b>F 1</b>	TE-5 19396 $\times$	800 mA	slow	UL. CSA
<b>F 2</b>	TE-5 19396 $\times$	1.25, A	<b>slow</b>	UL. CSA
<b>F 3</b>	<b>TE-5</b> 19396 $\times$	1.6 A	<b>slow</b>	UL. CSA

 $\times$  : or equivalents

Maker : Wickmann

(Note) Fuses is not open in the case **current** capacity of **power** supply is small. Or fuses is open by surge current in **case of** current capacity of power supply is big. In consequence please you **thoroughly** investigate the unit.

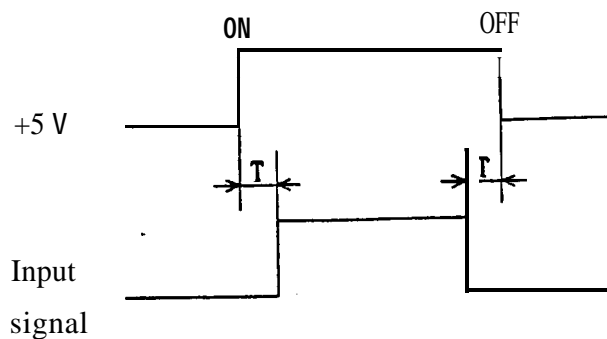
(b) Recommendation : **Power** on/off sequence

Note)  $T \geq 0$  shall be kept.

**SHARP**

(c) Take account of the **sheme** below for 5 VDC input  
rising up time and falling down time of 5 VDC

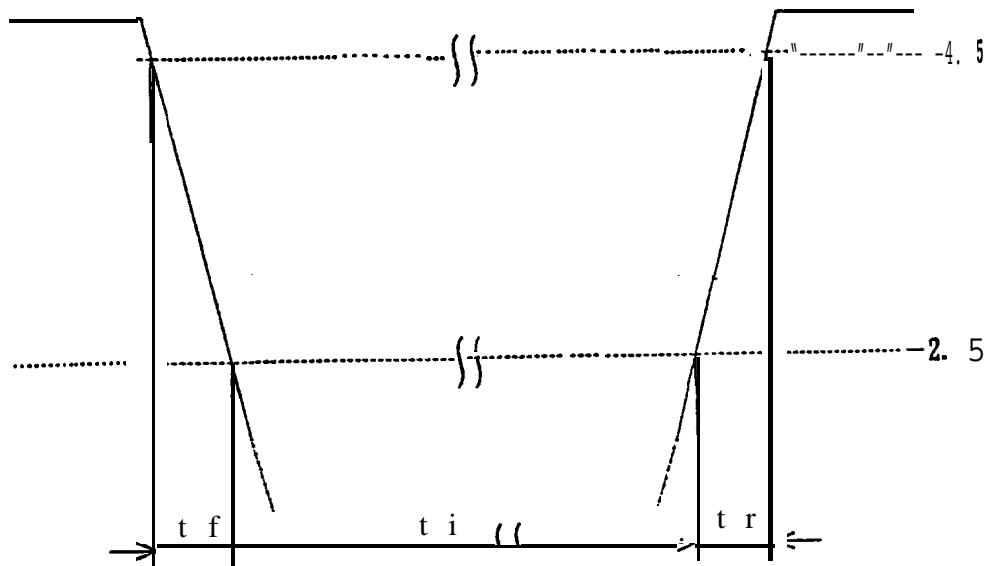

$t_f$  = falling down time     $t_r$  = rising up time

- (1)  $t_f, t_r \leq 100$  ms is better--to be kept.
- (2)  $t_i \geq 1$  ms shall be kept.



**SHARP**

13. Circuit scheme of the signal input block

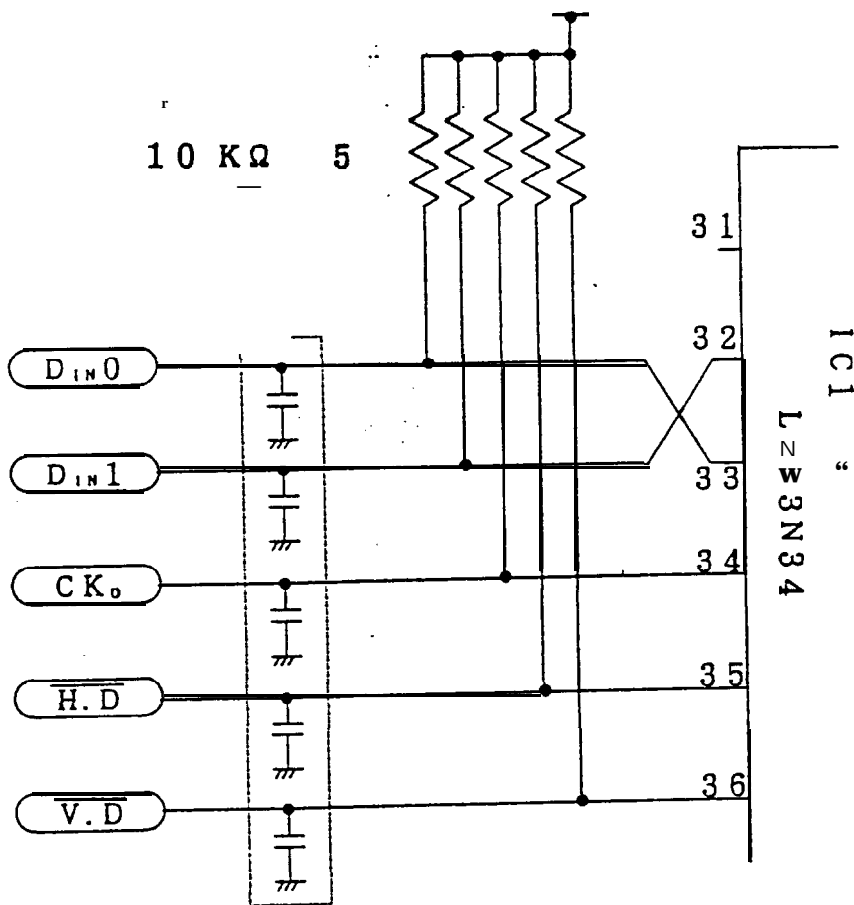

NFA81R00C220

(22 pF)

(Maker: MURATA MANUFACTURING COMPANY LIMITED)

**SHARP**

15. Packing Specification 10pcs. /packing

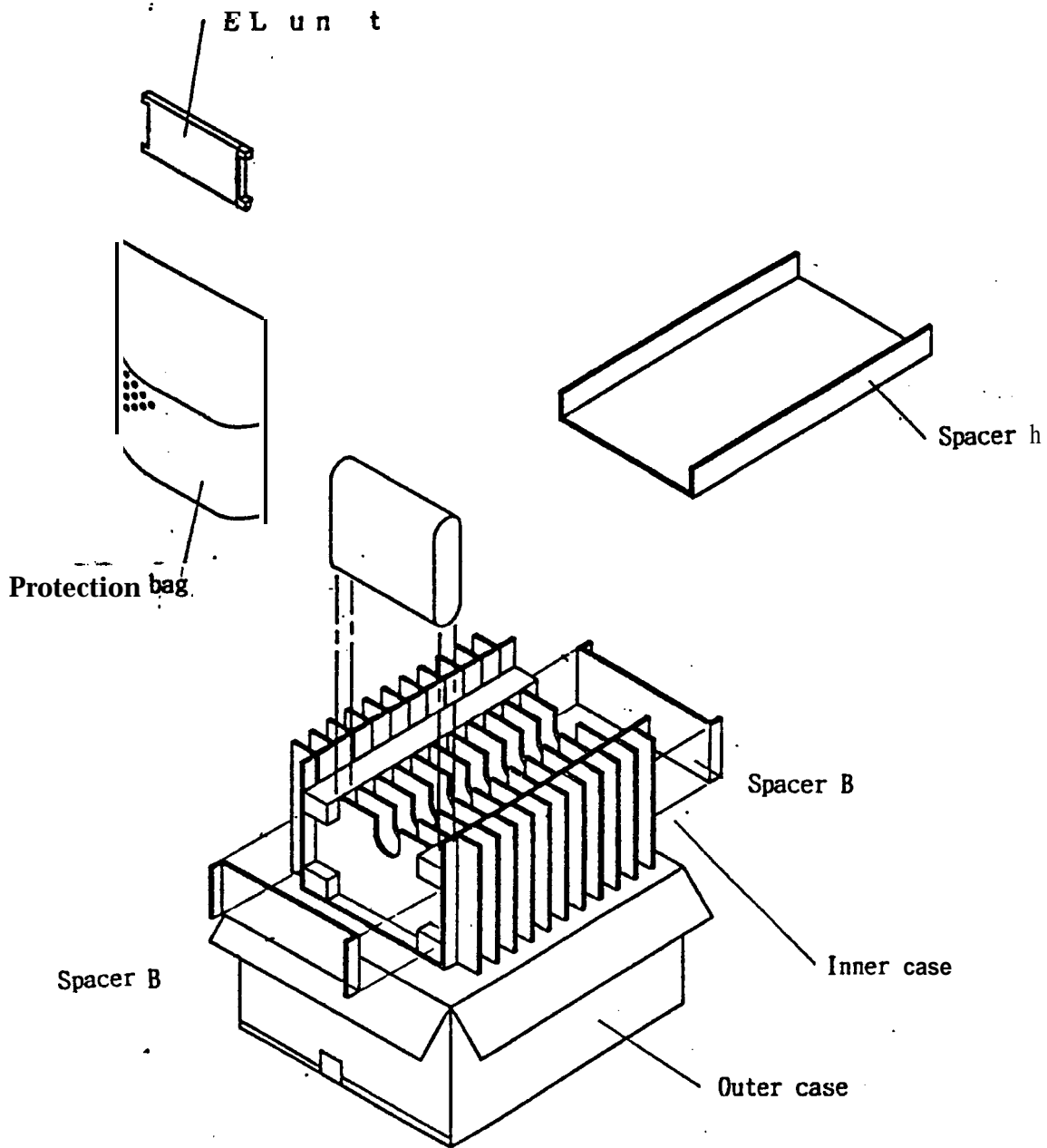

**SHARP**

Outline

